

# SKALS

*- we'll sort it out!*

## INSTRUCTION MANUAL

Roller Table type RBSP



A/S SKALS MASKINFABRIK  
HOVEDGADEN 56  
DK-8832 SKALS, DENMARK

Tlf.: +45 87 25 62 00

Fax: +45 86 69 49 99

[E-mail: Skals@skals.DK](mailto:Skals@skals.DK)

<http://www.skals.dk/>

CE



## Contents

1.0	Purpose and scope of operations	2
2.0	Installation	2
3.0	Operation	2
4.0	Pictograms	2
5.0	Lubrication and maintenance	3
5.1	Cleaning the machine	4
6.0	Packing and transport information	4
7.0	Transport and lifting instructions	5
8.0	Accessories	5
9.0	Spare parts	6
10.0	EU Declaration of Conformity	10



## 1.0 Purpose and scope of operations

The roller table is designed for the inspection and hand-sorting of potatoes, onions and similar products.

Normal operational working temperature: -15°C to + 40°C.

## 2.0 Installation

In order to ensure steady operation, the roller table must stand firmly on all four legs on a level floor. Adjust the legs so that the machine stands level.

If the roller table is to be positioned directly after a sorter, it is important that there is a safety clearance of at least 25 mm. between the roller table's inlet chute and the sorter's lowest riddle position.

Connect the electrical supply in accordance with local regulations. Connect the electricity supply to a relay corresponding to the size of the motor. If the machine is fitted with a relay, connect the supply to this.

**It is essential to check that all bolts, nuts and screws are properly tightened before commencing operation.**

## 3.0 Operation

When correctly assembled, start the roller table by activating the motor relay. Turn the light on at the switch.

## 4.0 Pictograms

Danger, moving parts at outlet. Keep a safe distance.



## 5.0 Lubrication and maintenance

All bearings, cylinder motors and cylinders are lubricated for life and require no further maintenance.

The worm drive type NMRV40 for the main conveyor is lubricated for life with IP TELIUM VSF, a synthetic grease suitable for a normal temperature range of  $-15^{\circ}\text{C}$  to  $+40^{\circ}\text{C}$ .

Grease quantity: 0.08 l.

### Recommended oils:

IP	Telium VSF
Shell	Tivela oil SC320
-249Agib	Blasia S320
Mobil	Glygoyle 30

Change oil after 5,000 production hours.

If the variator is mounted between the worm drive and the motor. It must always be kept filled with long life oil and should be topped up to the middle of the observation glass.

Change the oil every 8 years.

It is imperative that there is always the correct amount and type of oil in the variator.

### Recommended oils:

IP	Transmission V. E.
IP	A.T.F. Dexron Fluid
AGIP	A.T.F. Dexron
BP	Autran DX
Chevron	A.T.F. Dexron
ESSO	A.T.F. Dexron
Fina	A.T.F. Dexron
Mobil	A.T.F. 220
Shell	A.T.F. Dexron
Castrol	TQ Dexron II.



## 5.1 Cleaning

With reference to the Danish Plant Directorate's Order No. 965 of 13 December 1993 (p. 6).

- 2.3.3. Seed potato growers with contained propagation must clean and disinfect all sorting and ancillary equipment after each new variety. Disinfecting should be carried out using a product approved by The Danish Institute of Plant and Soil Science.
- 2.3.4. Companies authorized to sort potatoes and who also have the authorization to propagate potatoes, must clean and disinfect sorting machinery etc. which is under the control of The Danish Plant Directorate before the sorting of own propagation is commenced. Disinfecting should be carried out using a product approved by The Danish Institute of Plant and Soil Science.
- 2.3.5. Premises and machinery etc. must be cleaned and disinfected each year before 30 June. Disinfecting must be carried out using a product approved by The Danish Institute of Plant and Soil Science.

In other countries, customers must conform to relevant, local food and hygiene regulations.

**When cleaning with high pressure equipment**, the following parts must be securely covered:  
Motor, variator, worm gear, and all bearings.

In order to maintain effective production and keep maintenance costs at a minimum, regular lubrication, maintenance and cleaning are very important.

## 6.0 Packing and transport information

Number of units:

The machine is packed complete as one unit.

<b>Weight:</b>	<b>Kg.</b>
RBSP620	215
RBSP820	250
RBSP1120	300

<b>Dimensions:</b>	<b>Length</b>	<b>Width</b>	<b>Height</b>
RBSP620	2450	900	1700
RBSP820	2450	1100	1700
RBSP1120	2450	1400	1700

## 7.0 Transport and lifting instructions

Should it be necessary to lift the Roller Table, this **must** be carried out by using nylon straps fitted to the four legs, as shown in the illustration below (fig. 1).

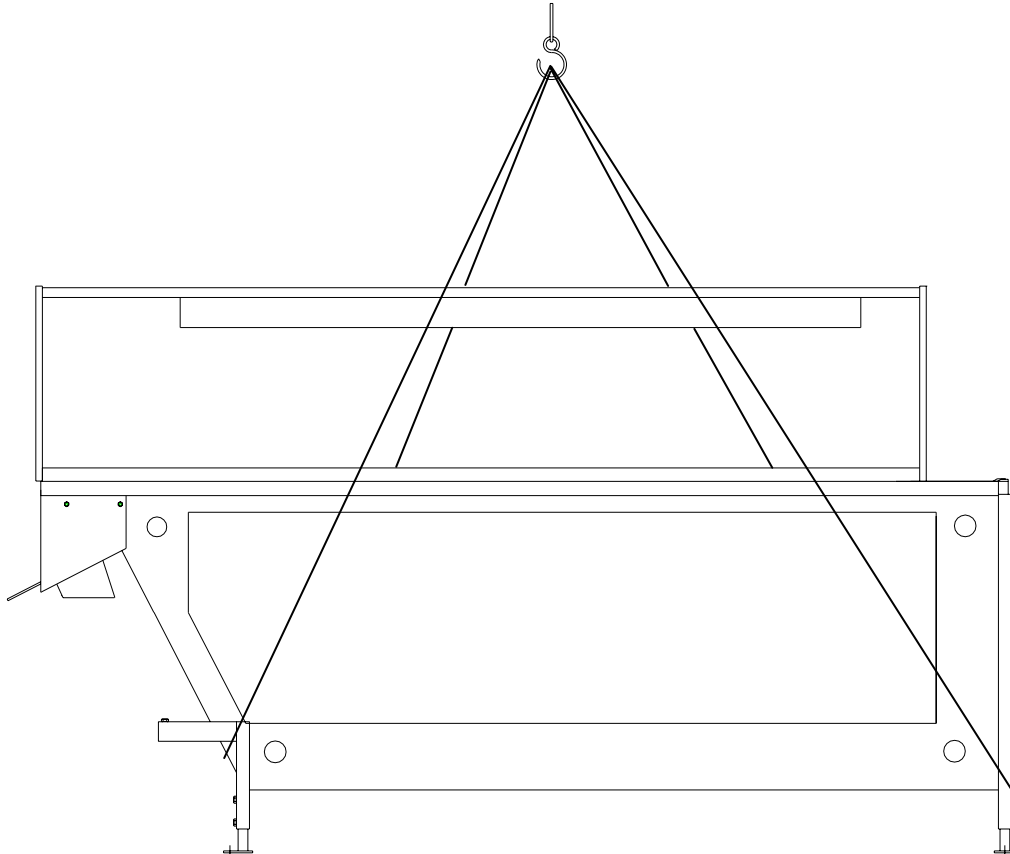

Fig. 1

## 8.0 Accessories

The roller table can be supplied with the following accessories:

<u>Part. no.</u>		<u>Part. no.</u>	
4 69 20 000	Variator	4 12 99 880	Hand rail
4 12 99 800	Light fitting	4 12 99 850	Ladder
4 12 99 980	Light installation (2000-2500)	4 12 99 820	Steps
4 12 99 525	Mounting for waste conveyor	4 12 01 000	Motor relay type 1
4 12 99 770	Waste channel (side-mounted)	4 12 10 000	Control box type 3.
4 12 99 740	Waste channel (mid-mounted)	4 12 08 000	Light connector
4 09 99 910	Waste chute on side	4 12 15 000	Control box type 8.
4 12 99 680	Waste chute (side-mounted)	4 12 06 000	Connector, electrical
4 12 99 650	Extendable legs	4 12 05 000	Main switch
4 12 99 910	Platform		

## 9.0 Spare parts

When ordering spares, state machine type, serial no. and, if possible, position no.

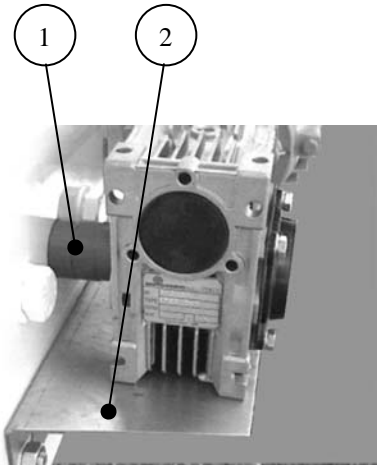

Fig. 2

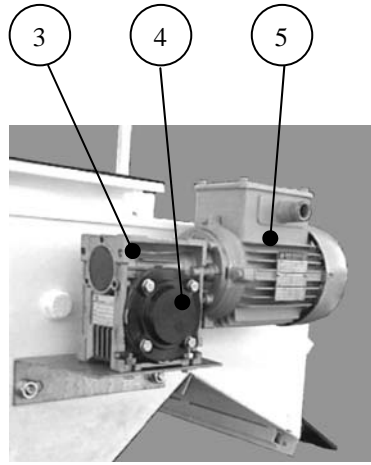

Fig. 3

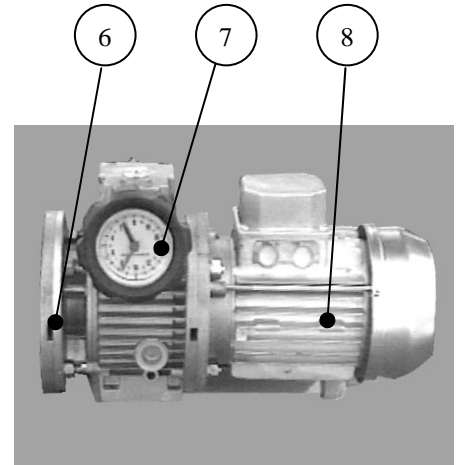

Fig. 4

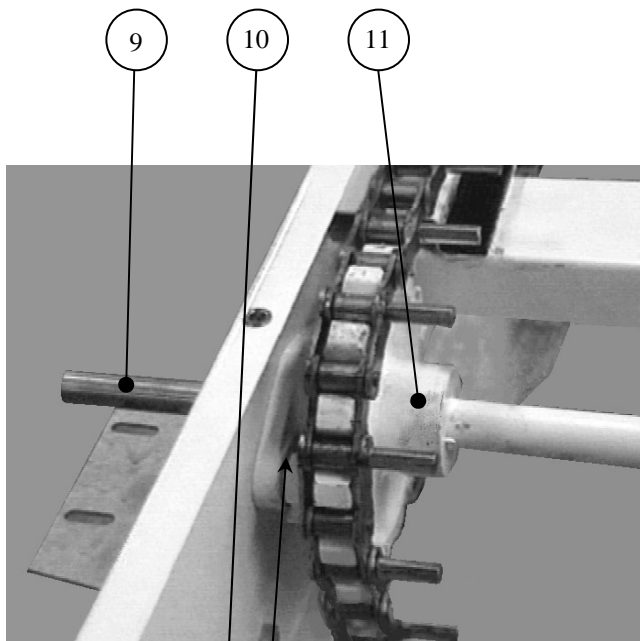

Fig. 5

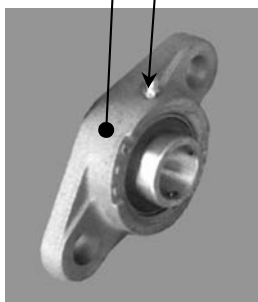

Fig. 6

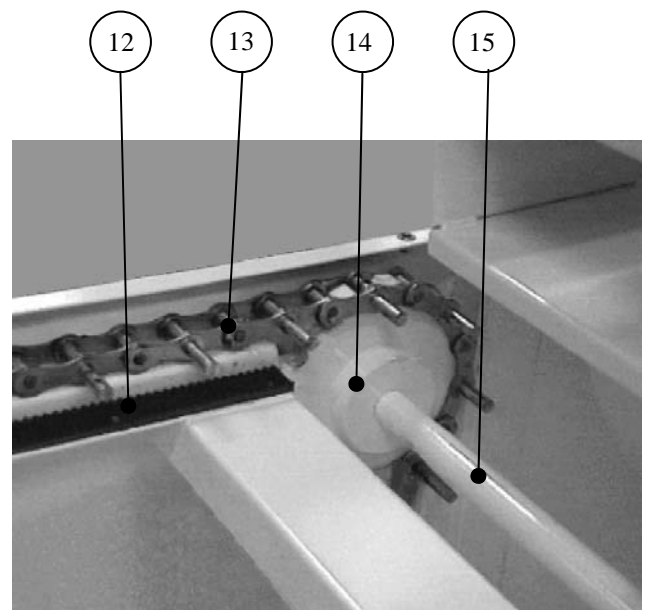

Fig. 7

Fig. 8

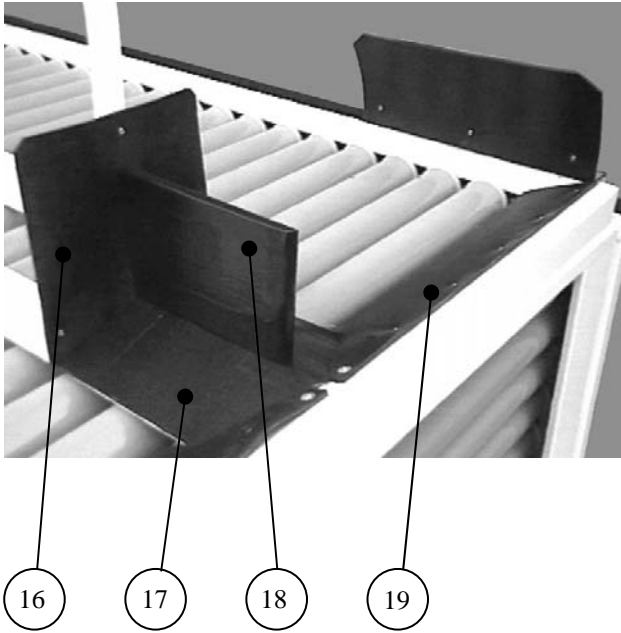

Fig. 9

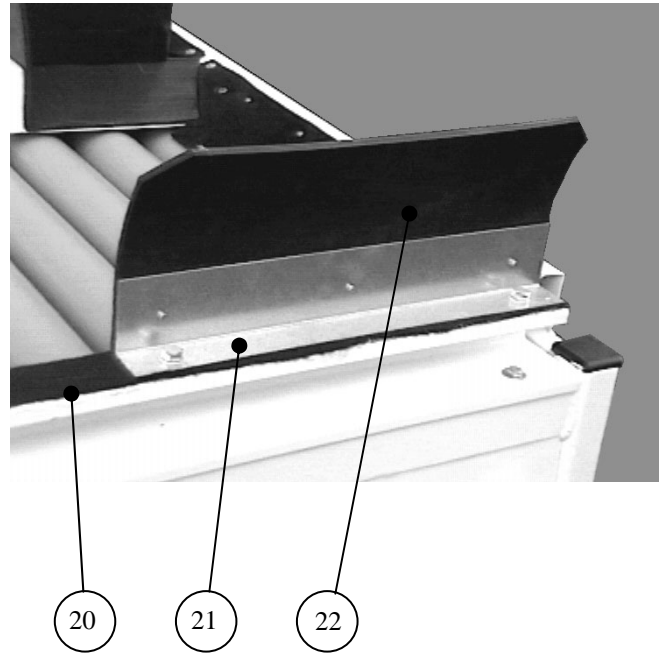

Fig. 10

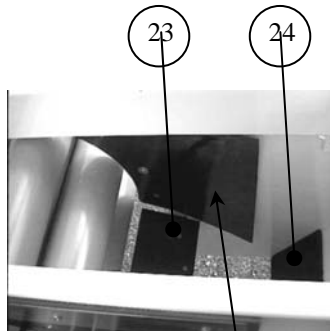

Fig. 11



Fig. 12

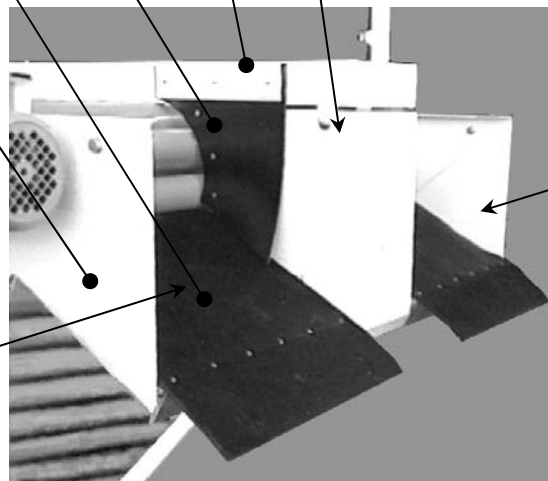
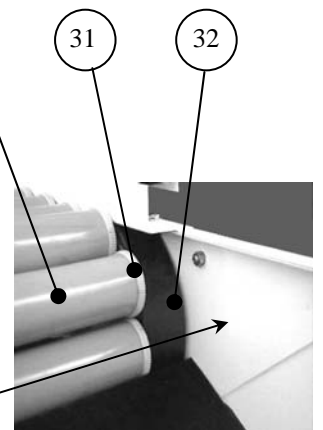
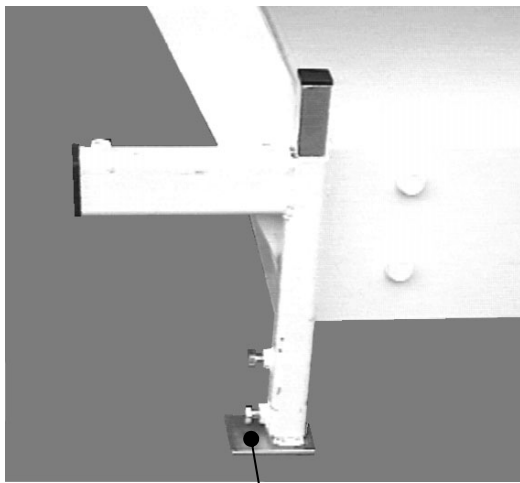
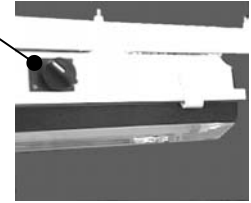
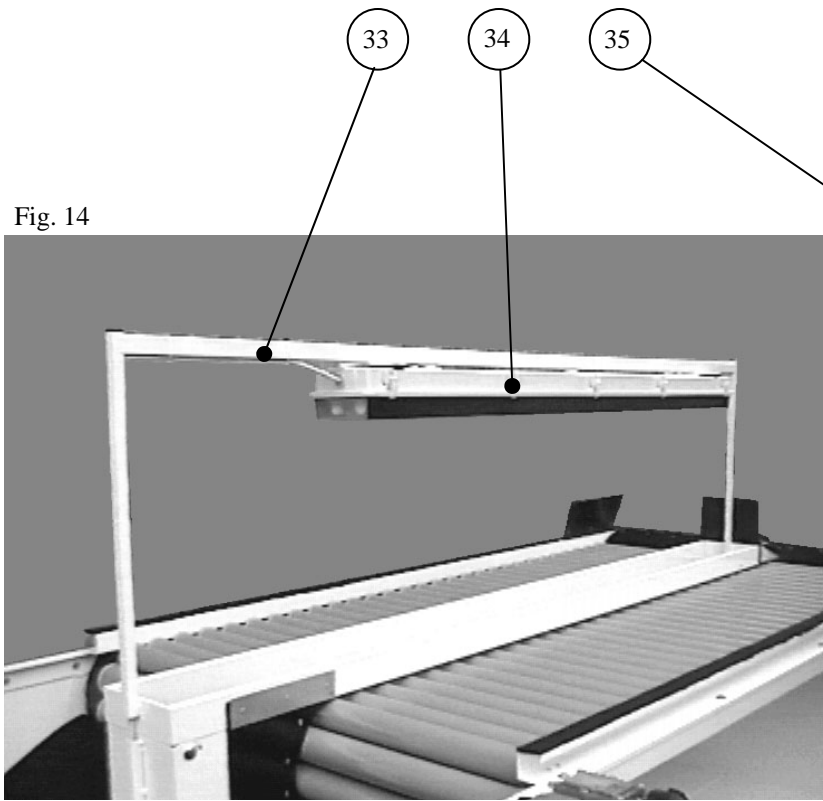

Fig. 13







Page	Fig. no.	Pos. no.	Description
6	2	1	Shielding
6	2	2	Gear motor mounting
6	3	3	Gear
6	3	4	Cover
6	3	5	Motor
6	4	6	Variator
6	4	7	Clock
6	4	8	Motor
6	5	9	Drive axle
6	6	10	Bearing
6	5	11	Driving sprocket
6	7	12	Super-grib
6	7	13	Chain
6	7	14	Sprocket
6	7	15	Axle
7	8	16	Rubber shield
7	8	17	Rubber shield
7	8	18	Rubber shield
7	8	19	Rubber shield
7	9	20	Felt
7	9	21	Rubber shield
7	9	22	Bracket for rubber shield
7	10	23	Rubber shield
7	10	24	Rubber shield
7	11	25	Foam rubber sheet
7	12	26	Outlet chute (unit)
7	12	27	Rubber shield
7	12	28	Rubber separator
7	12	29	Bracket for rubber shield
7	13	30	Complete roller
7	13	31	End bearing
7	13	32	Rubber shielding
8	14	33	Light unit rail
8	14	34	Light armatur
8	15	35	Switch
8	16	36	Adjustable leg
8	17	37	Adjustable leg
8	17	38	Tension



**Declaration of conformity with EU.**

<b>Manufacturer</b>	
Firm:	A/S Skals Maskinfabrik
Address:	Hovedgaden 56 8832 Skals, Denmark
Telephone:	87 25 62 00

declares herewith, that

<b>Machine:</b>	<b>Roller table</b>
Brand:	<b>RBSP</b>
Type, serial no., year:	

Is manufactured in accordance with the decisions of the Councils Directives:

- 1 Machinery Safety – Directive 98/37/EC
- 2 Low Voltage Equipment Directive (LVD) 2006/95/EEC
- 3 Electromagnetic Compatibility (EMC) Directive 89/336/EEC and 93/68/EEC as amended.

<b>Title:</b>	Productions Manager
<b>Name:</b>	Søren Lund Madsen
<b>Firm:</b>	A/S Skals Maskinfabrik

Date: \_\_\_\_\_

Signed: \_\_\_\_\_

